



FERRI[®]

VOTEX[®]

Forestry



Gamma di trinciatrici forestali per la manutenzione professionale delle aree boschive.

Range of forestry mulchers for professional maintenance of wooded areas.

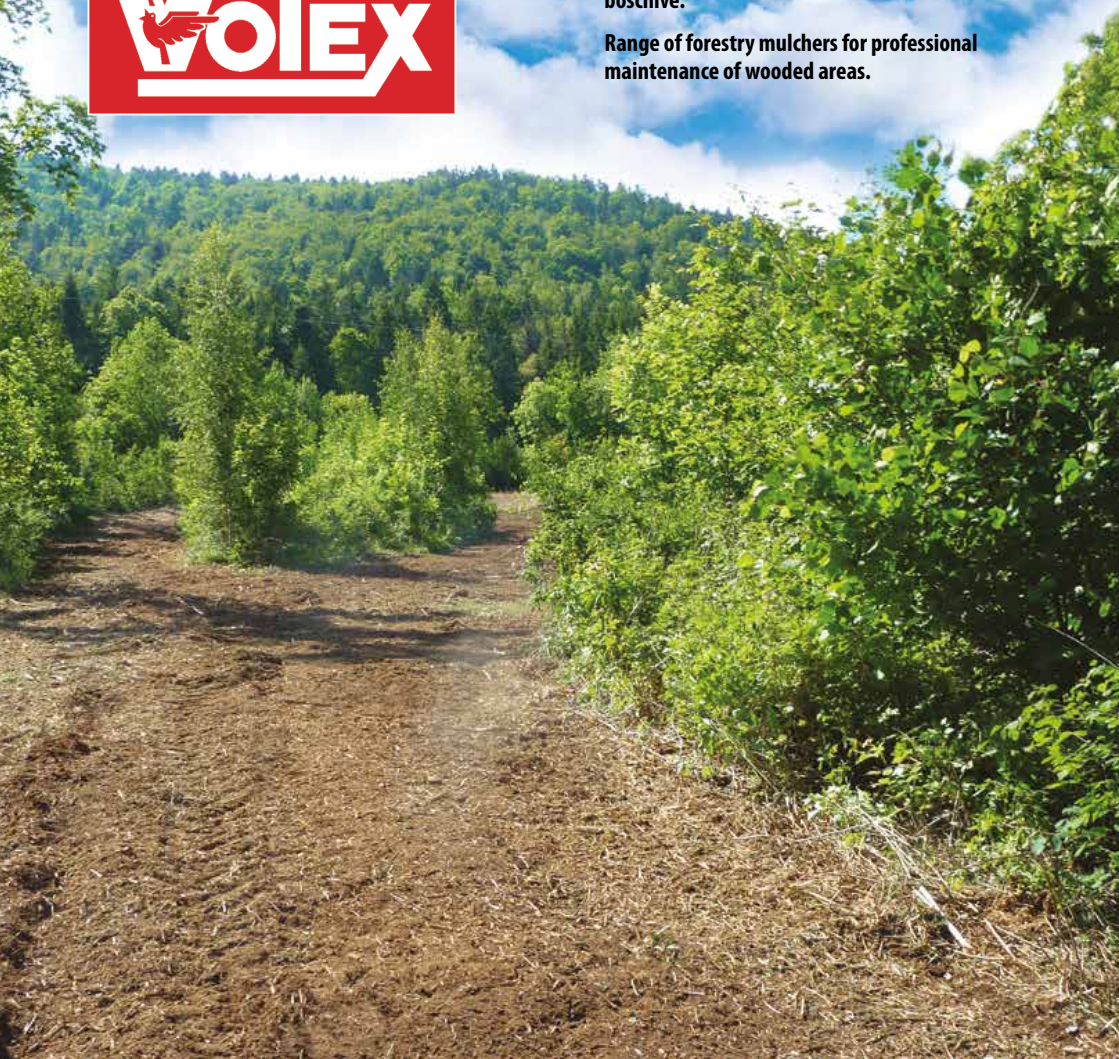

TFCB/F



TFC



TFC-DT



180 anni di storia

Dal 1844 e da sei generazioni, Ferri è sinonimo di innovazione tecnologica. Un'evoluzione ottenuta puntando sempre su ricerca e sviluppo di macchine per la manutenzione del verde pubblico e agricolo.

Oggi la Ferri con una produzione e vendita di oltre 35.000 macchine in tutto il mondo, si colloca tra le aziende leader del settore in Europa.

180 years of history

Since 1844 and for six generations, Ferri has been synonymous with Technological Innovation. This evolution has been achieved through continuous focus on the research and development of machines for the maintenance of public and agricultural greenery.

Today, Ferri is one of the industry's leading companies in Europe with production and sales of more than 35,000 machines worldwide.



1844 - Le origini / The origins



La sicurezza e la qualità per il nostro futuro

Lo spirito innovativo che ha caratterizzato, da sempre, la progettazione e la produzione dei prodotti della Ferri si è sempre basato su concetti semplici ma efficaci, miglioramento del comfort dell'operatore che significa maggiore sicurezza, fare tesoro dei suggerimenti di chi lavora tutti i giorni con i prodotti Ferri, ricerca costante della migliore qualità sul mercato stringendo collaborazioni strategiche, di lungo termine, con i migliori fornitori nazionali ed internazionali.

Tutto questo in sintesi è alla base dell'ultima nata in casa Ferri, **il porta-attrezzi radiocomandato iCUT 3,60**, progettato in collaborazione con studi tecnici all'avanguardia, non solo nel settore agricolo, che ha come obiettivo, offrire una valida alternativa, in totale sicurezza, a chi è chiamato ad operare in condizioni difficilmente praticabili con i mezzi tradizionali.

La stessa linea guida che ha permesso di ottenere dal 2016 il prestigioso marchio di **UnimogPartner by Mercedes-Benz**, grazie allo sviluppo di un modello Ferri dedicato per risolvere specifiche esigenze operative della gamma Unimog.

**Ferri, il futuro premia
chi crede nel futuro.**

Safety and quality for our future

The innovative spirit that has always characterised the design and production of Ferri products has always been based on simple yet effective concepts, such as improved operator comfort for greater safety, making the most of suggestions from those who work with Ferri products on a daily basis, consistently seeking the best quality on the market and solidifying long-term strategic partnerships with the best national and international suppliers.

All of this underpins the latest Ferri product, **the iCUT 3.60 remote controlled carrier machine**, designed in conjunction with state-of-the-art technical studies, not just in the agricultural sector, which aims to provide a viable and completely safe alternative for those operating in difficult conditions with traditional means.

The same guideline has allowed us to attain the prestigious **UnimogPartner by Mercedes-Benz** brand from 2016, thanks to the development of a Ferri model designed for the specific operating needs of the Unimog. range.

**Ferri, the future rewards
those who believe in the future.**

1844

Giovanni Ferri
fonda la FERRI
founded FERRI

1923

Giovanni Ferri
meccanico
nell' officina FERRI
mechanic in the
FERRI workshop

1952

Produzione macchine per
la canapa
Production of
hemp machines

1968

Produzione
fresatrice interfilare
Production of
inter-row rotary tiller

1970

Presentazione
della prima trinciatrice
Presentation of
the first mower

1980

Presentazione
del primo braccio
decespugliatore
Presentation of
the first
reach mowers

1989

Presentazione
del braccio
decespugliatore
ventrale
Presentation of
hydraulic reach
mowers

2001

Fondazione
FERRI France
Founding of
FERRI France

2013

Presentazione
del porta attrezzi
radiocomandato iCut
Presentation of
iCut remote controlled
carrier machine

NUOVI ROTORI DENTI FISSI CON RINFORZI AL TUNGSTENO NEW FIXED TEETH ROTORS WITH TUNGSTEN REINFORCEMENTS

ROTORE APEIRON APEIRON ROTOR

denti fissi con riporti al tungsteno
e rotore con profili in acciaio.
*fixed tooth with tungsten coating
and rotor with steel profiles.*

ROTORE ROTOR

con utensili fissi.
with fixed tooth.

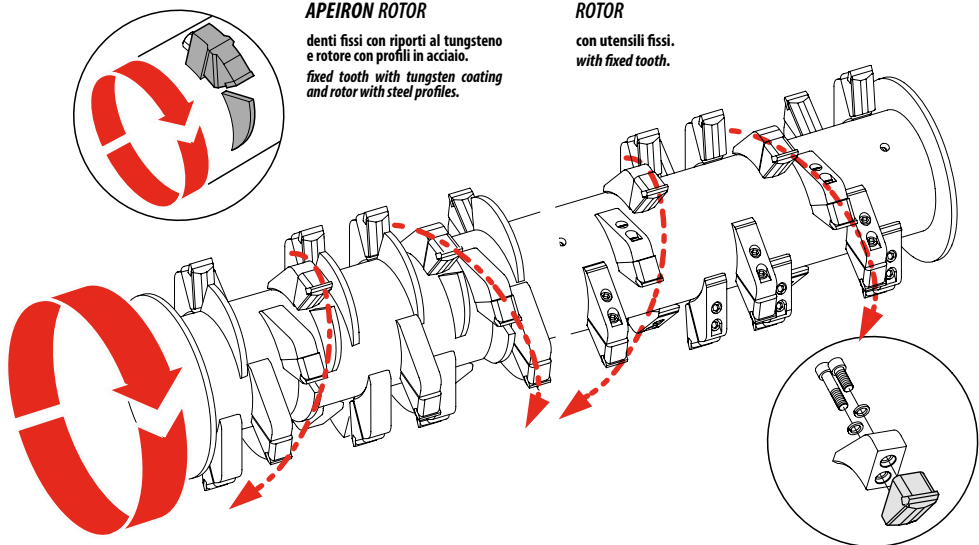

ROTORE APEIRON / APEIRON ROTOR

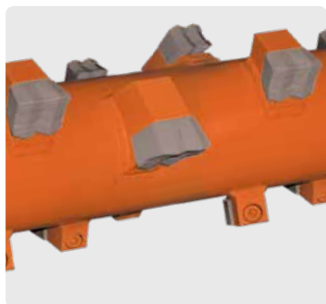

ROTORE / ROTOR

Nuovo Rotore Apeiron Il nuovo rotore Apeiron unisce i vantaggi del rotore a denti fissi agli enormi vantaggi derivanti dalla presenza di particolari profili in HARDOX saldati sequenzialmente sul rotore ed allineati ai supporti dei denti, che per la loro posizione e forma garantiscono una graduale penetrazione dei denti fissi nel materiale da trinciare garantendo uno sforzo omogeneo all'impianto idraulico dell'escavatore.









Disponibilità di nuovi motori.

Su richiesta sono disponibili nuovi motori a cilindrata variabile.

The new Apeiron rotor combines the advantages of the fixed tooth rotor to the enormous advantages deriving from the presence of Hardox profiles welded sequentially on the rotor and aligned with the tooth supports, that for their position and shape guarantee a gradual penetration of the fixed teeth into the material to be chopped guaranteeing a homogeneous effort to the hydraulic system of the excavator. Increased productivity and lower fuel consumption.

New engines available.

New variable displacement engines are available on request.

| Mod. | min  max | | min HP max | Utensili di taglio Cutting flails | Pagina Page |
|--|---|-----------|------------|---|----------------|
| | m | ft | | | |
| TFCB/F-R  | 1,60 - 1,80 | 5.2 - 5,9 | 60-90 |  | 6 |
| TFCB/F | 1,80 - 2,00 | 5.9 - 6.6 | 70-120 |  | 8 |
| TFC/F | 1,80 - 2,20 | 5.9 - 7.3 | 100-140 |  | 10 |
| TFC/A | 1,80 - 2,20 | 5.9 - 7.3 | 100-140 |  | 12 |
| TFC-DT/F | 2,00 - 2,20 | 6.6 - 7.3 | 120-180 |  | 14 |
| TFC-DT/A | 2,00 - 2,20 | 6.6 - 7.3 | 120-180 |  | 16 |



FERRI**TFCB/F****VOTEX**

TRINCIATRICI FORESTALI - ROTORE CON UTENSILI FISSI
PER TRATTRICI DA 60÷90 HP (Ø max 20 cm - 7.87 in)
FORESTRY MULCHERS - ROTOR WITH FIXED TOOLS
FOR TRACTORS FROM 60 - 90 HP (Ø max 20 cm - 7.87 in)



Il modello TFCB completa la sua gamma con la nuova versione RIBASSATA disponibile adesso nelle larghezze di lavoro di 1,60 e 1,80 cm.

Questa nuova versione è ideale per lavorare con trattori con potenze tra 60 - 90 HP per trinciare ramaglie, cespugli fino ad un diametro massimo di 20 cm.

Già a livello progettuale sono state definite le dimensioni contenute del telaio e l'altezza ridotta della presa di forza per permettere di utilizzare il cardano in condizioni di sicurezza e tranquillità.

Questo permette il perfetto accoppiamento ottimale con i trattori predisposti per lavorare nei vigneti o nei frutteti e soprattutto di operare in condizioni di pendenza con la sicurezza che tutti gli organi meccanici siano nelle condizioni perfette per il loro corretto funzionamento.

Particolare attenzione è stata prestata poi al telaio, rinforzandolo adeguatamente, per sostenere nel tempo i carichi assiali provocati dalle movimentazioni particolari dei trattori cingolati.



Rotore con utensili fissi
Rotor with fixed tools

HARDOX[®]
 WEAR PLATE
DOMEX[®]
 HIGH STRENGTH STEEL

Versione con presa di forza ribassata per l'utilizzo in terreni in pendenza con trattori con pdf bassa.
For use in sloping terrain and suitable for tractors with lower PTO



The TFCB model extends its range with the new LOW version now available in working widths of 1.60 and 1.80 cm.

This new development is ideal for working with tractors with 60 - 90 HP to mow branches, bushes up to a maximum diameter of 20 cm.

Defined already at the design level were the small dimensions of the frame and the low height of the PTO to allow safe and easy use of the PTO shaft.

This allows the perfect optimal setting with tractors to work in vineyards or orchards and, above all, to operate on slopes with the confidence that all mechanical parts are in the perfect condition for their proper operation in full safe.

Special attention was then given to the frame, reinforcing it properly to withstand the axial loads caused by the special handling of crawler tractors over time.



Rotore con utensili fissi.
 Rotor with fixed tools.



Controllo telaio HARDOX 400.
 HARDOX 400 lining.



Trasmissione laterale a 4 cinghie.
 Lateral 4-belts drive.



Slitte di appoggio.
 Skids.



Doppia protezione anteriore con catene.
 Double front guard with chains.

INFORMAZIONI TECNICHE - TECHNICAL DATA

| Modello Model | | | | | | | | |
|------------------|------|------|---------|---------|------|------|------|------|
| | m | ft | HP | kW | m | ft | m | lb |
| TFCB/F 1600R | 1,60 | 5.25 | 60 - 80 | 45 - 60 | 0,25 | 0.82 | 0,41 | 2.00 |
| TFCB/F 1800R | 1,80 | 5.90 | 70 - 90 | 52 - 67 | 0,25 | 0.82 | 0,41 | 2.00 |

| Modello Model | | | | |
|------------------|-----|---|-----|-------|
| | rpm | n | Kg | lb |
| TFCB/F 1600R | 540 | 4 | 750 | 1.653 |
| TFCB/F 1800R | 540 | 4 | 820 | 1.807 |

Dotazione standard

- Attacco universale a 3 punti ISO di 2° cat.
- Gruppo moltiplicatore pdf 540 giri/minuto.
- Telaio in Domex 700.
- Controtelaio interno in "Hardox 400".
- Cofano posteriore regolabile idraulicamente.
- Slitte regolabili in altezza sostituibili.
- Trasmissione laterale a cinghie.
- Tendinghie regolabile.
- Utensili fissi: con inserti al carburo di tungsteno.
- Protezione anteriore con catene doppie.
- Albero cardanico con bullone di trancio.
- Protezioni antifortunistiche «CE».

Accessori

- Abbattirami

Standard equipment

- Universal three point linkage ISO cat. 2.
- 540 RPM PTO gearbox.
- Structural frame in Domex 700.
- Hardox 400 lining.
- Hydraulically adjustable rear guard.
- Replaceable height-adjustable skids.
- Transmission with belt drives.
- Adjustable belt tensioners.
- Ferri forestry fixed with tungsten carbide inserts.
- Front guards with double chains.
- PTO shaft with bolt.
- Accident prevention protections according to EC directives.

DIMENSIONI - DIMENSIONS

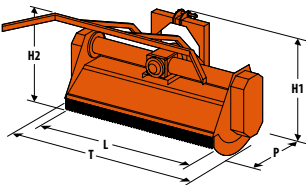

| | T | | L | | P | | H1 | | H2 | |
|--------------|------|------|------|------|------|------|------|------|------|------|
| | m | ft | m | ft | m | ft | m | ft | m | ft |
| TFCB/F 1600R | 1,85 | 6.07 | 1,60 | 5.25 | 0,93 | 3.04 | 0,99 | 3.25 | 1,33 | 4.36 |
| TFCB/F 1800R | 2,05 | 6.73 | 1,80 | 5.91 | 0,93 | 3.04 | 0,99 | 3.25 | 1,54 | 5.05 |

UTENSILI DA TAGLIO - CUTTING FLAILS

| Con rotore dedicato With dedicated rotor | | TFCB/F 1600R | TFCB/F 1800R | | |
|--|--|--------------|--------------|------|------|
| | | Nr. - No. | Nr. - No. | Ø cm | Ø in |
| Utensili fissi reversibili con inserti al carburo di tungsteno Fixed and reversible tools with tungsten carbide inserts | | 33 | 39 | 20 | 7.87 |

Accessories

- Push-over bar

FERRI[®]**TFCB/F**

TRINCIATRICI FORESTALI - ROTORE CON UTENSILI FISSI
PER TRATTRICI DA 70÷120 HP (Ø max 20 cm - 7.87 in)
FORESTRY MULCHERS - ROTOR WITH FIXED TOOLS
FOR TRACTORS FROM 70 - 120 HP (Ø max 20 cm - 7.87 in)

Le trinciatrici forestali modello TFCB/F sono ideali per trinciare ramaglie e cespugli fino a 20 cm di diametro in combinazione con piccole e medie trattatrici. Indicate per la manutenzione di strade, linee elettriche e pulizia del bosco dopo la raccolta del legname.

La trincia forestale, modello TFCB/F è dotata nella sua versione standard, di un rotore robusto con utensili fissi. Gli utensili ed i loro supporti sono in acciaio forgiato ad altissima resistenza con inserti al carburo di tungsteno. Il rotore a denti fissi permette un limitato consumo di potenza del trattore soprattutto nelle fasi di avvio lavori ed una lunga durata nel tempo. La sostituzione dei denti è rapida e semplice in tutte le condizioni di lavoro.

The TFCB/F model forestry mulcher are ideal for shredding branches and bushes up to 20 cm in diameter in combination with small and medium tractors. Suitable for the maintenance of roads, power lines and forest cleaning after timber harvesting.

The standard version of the TFCB/F forestry mulcher is equipped with a rugged rotor with fixed tools. The tools and their supports are made of high-strength forged steel with tungsten carbide inserts. The rotor with fixed teeth allows a limited power consumption of the tractor, especially during the start of work and a long life in time. The replacement of the tines is quick and easy in all working conditions.



HARDOX[®]
 WEAR PLATE
DOMEX[®]
 HIGH STRENGTH STEEL

Rotore con utensili fissi
Rotor with fixed tools



Rotore con utensili fissi.
 Rotor with fixed tools.



Controltelaio HARDOX 400.
 HARDOX 400 lining.



Trasmissione laterale a 4 cinghie.
 Lateral 4-belts drive.









Slitte di appoggio.
 Skids.



Doppia protezione anteriore con catene.
 Double front guard with chains.

INFORMAZIONI TECNICHE - TECHNICAL DATA

| Modello Model |  | |  min max | |  | |  | |
|--------------------|---|------|---|---------|---|------|---|------|
| | m | ft | HP | kW | m | ft | m | lb |
| TFCB/F 1800 | 1,80 | 5.90 | 70 - 90 | 52 - 67 | 0,25 | 0.82 | 0,41 | 2.00 |
| TFCB/F 2000 | 2,00 | 6.56 | 90 - 120 | 67 - 89 | 0,25 | 0.82 | 0,41 | 2.00 |

| Modello Model |  |  |  |
|--------------------|---|---|---|
| | rpm | n | Kg lb |
| TFCB/F 1800 | 540 | 4 | 960 2.116 |
| TFCB/F 2000 | 540 | 4 | 1.080 2.380 |

Dotazione standard

- Attacco universale a 3 punti ISO di 2° cat.
- Gruppo moltiplicatore pdf 540 giri/minuto.
- Telaio in Domex 700.
- Controtelaio interno in "Hardox 400".
- Cofano posteriore regolabile idraulicamente.
- Slitte regolabili in altezza sostituibili.
- Trasmissione laterale a cinghie.
- Tendicinghie regolabile.
- Utensili fissi: con inserti al carburo di tungsteno.
- Protezione anteriore con catene doppie.
- Albero cardanico con bullone di trancio.
- Protezioni antifortunistiche «CE».

Accessori

- Abbattirami

Standard equipment

- Universal three point linkage ISO cat. 2.
- 540 RPM PTO gearbox.
- Structural frame in Domex 700.
- Hardox 400 lining.
- Hydraulically adjustable rear guard.
- Replaceable height-adjustable skids.
- Transmission with belt drives.
- Adjustable belt tensioners.
- Ferri forestry fixed with tungsten carbide inserts.
- Front guards with double chains.
- PTO shaft with bolt.
- Accident prevention protections according to EC directives.



Accessories

- Push-over bar

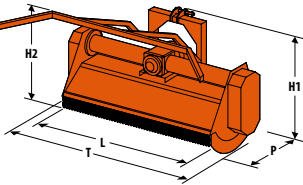
DIMENSIONI - DIMENSIONS

|  | T | | L | | P | | H1 | | H2 | |
|---|--------------------|------|------|------|------|------|------|------|------|------|
| | m | ft | m | ft | m | ft | m | ft | m | ft |
| | TFCB/F 1800 | 2,05 | 6.73 | 1,80 | 5.91 | 0,93 | 3.04 | 1,21 | 3.96 | 1,54 |
| TFCB/F 2000 | 2,25 | 7.38 | 2,00 | 6.56 | 0,97 | 3.18 | 1,21 | 3.96 | 1,54 | 5.05 |

UTENSILI DA TAGLIO - CUTTING FLAILS

| Con rotore dedicato With dedicated rotor | TFCB/F 1800 | TFCB/F 2000 |  | | | |
|--|---|---|---|------|----|------|
| | Nr. - No. | Nr. - No. | Ø cm | Ø in | | |
| Utensili fissi reversibili con inserti al carburo di tungsteno Fixed and reversible tools with tungsten carbide inserts |  |  | 39 | 45 | 20 | 7.87 |

FERRI®**TFC/F****VOTEX**®

TRINCIATRICI FORESTALI - ROTORE CON UTENSILI FISSI
PER TRATTRICI DA 100 ÷ 140 HP (Ø max 25 cm - 9.84 in)
FORESTRY MULCHERS ROTOR WITH FIXED FLAILS
FOR TRACTORS FROM 100 to 140 HP (Ø max 25 cm - 9.84 in)

La gamma di potenti trinciatrici forestali TFC, è espressamente dedicata alla manutenzione del verde incolto e boscaglia, alla creazione e manutenzione di strade tagliafuoco, argini e ferrovie contaminati da arbusti, ecc. Le caratteristiche principali di queste macchine sono il telaio interamente in acciaio ad alto indice di snervamento, dal controtelaio interno rivestito in HARDOX 400 e dal rotore che, con mazze forgiate o utensili fissi, assicura un diametro di taglio fino a 25 cm. L'irrobustimento delle fiancate aumenta la tenuta del corpo macchina evitando possibili incrinature dovute a strappi e pressioni. Altri particolari importanti sono: il martinetto idraulico per apertura cofano, i 2 controcoltelli con spessore da 20 mm, le slitte di appoggio di grossa sezione, la trasmissione a 5 cinghie, le protezioni anteriori con 2 file di catene, ecc.



HARDOX®
WEAR PLATE

Rotore con utensili fissi
Rotor with fixed tools



The range of powerful forestry mulchers series TFC is specifically designed for the maintenance of set-aside areas, overgrown bushes, fire roads clearance, maintenance of embankments and railways side areas covered with heavy shrubs and so on, basically in all situations which can not be addressed with traditional agricultural shredders. The main features of these machines are: frame made of high yield steel, subframe made of wear-resistant steel (Hardox 400), a very versatile rotor whose forged hammers or fixed tooth, ensure a cutting diameter of up to 25 cm. The strong side plates increase the tightness of the main body, thus avoiding possible cracks due to tearing and torques. Other important details are: hydraulic cylinder for opening the hood, 2 thick counter-knives of 20 mm, wide side skids, side transmission with belts, front guards with 2 rows of chains and so on.



Rotore con utensili fissi.
Rotor with fixed tools.



Controtelaio HARDOX 400.
HARDOX 400 lining.



Trasmissione laterale a 5 cinghie e cofani con martinetti.
Lateral 5-belt drive and hood with hydraulic cylinders.









Slitte di appoggio.
Skids.



Doppia protezione anteriore con catene.
Double front guard with chains.

INFORMAZIONI TECNICHE - TECHNICAL DATA

| Modello Model |  | |  | |  | |  | |
|------------------|---|------|---|----------|---|------|---|------|
| | m | ft | HP | kW | m | ft | m | lb |
| TFC/F 1800 | 1,80 | 5.90 | 100 - 120 | 75 - 90 | 0,28 | 0.92 | 0,50 | 1.64 |
| TFC/F 2000 | 2,00 | 6.56 | 120 - 130 | 90 - 97 | 0,28 | 0.92 | 0,50 | 1.64 |
| TFC/F 2200 | 2,20 | 7.22 | 120 - 140 | 90 - 104 | 0,28 | 0.92 | 0,50 | 1.64 |

| Modello Model |  |  |  | |
|------------------|---|---|---|-------|
| | rpm | n | Kg | lb |
| TFC/F 1800 | 1.000 | 5 | 1.530 | 3.373 |
| TFC/F 2000 | 1.000 | 5 | 1.670 | 3.672 |
| TFC/F 2200 | 1.000 | 5 | 1.810 | 3.990 |

Dotazione standard

- Attacco universale a 3 punti ISO di 2° cat.
- Gruppo moltiplicatore pdf 1000 giri/min. con ruota libera.
- Telaio in acciaio strutturale.
- Controtelaio interno in "Hardox 400".
- Cofano posteriore regolabile idraulicamente.
- Slitte con rinforzo antiusura regolabili in altezza sostituibili.
- Trasmissione laterale singola a cinghie.
- Tendinghie regolabile.
- Utensili fissi: con inserti al carburo di tungsteno.
- Protezione anteriore e posteriore con catene doppie.
- Albero cardanico con bullone di trancio.
- Presa di forza 1 3/8" = Z6.
- Doppia fila di controcoltelli.
- Piedino di appoggio.
- Protezioni antifortunistiche «CE».

Accessori

- Abbattirami.

DIMENSIONI - DIMENSIONS

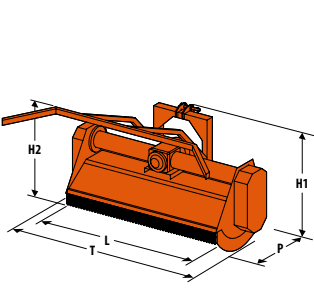
|  | T | | L | | P | | H1 | | H2 | |
|---|------------|------|------|------|------|------|------|------|------|------|
| | m | ft | m | ft | m | ft | m | ft | m | ft |
| | TFC/F 1800 | 2,00 | 6.56 | 1,80 | 5.91 | 1,01 | 3.31 | 1,04 | 3.41 | 1,50 |
| TFC/F 2000 | 2,20 | 7.22 | 2,00 | 6.56 | 1,01 | 3.31 | 1,04 | 3.41 | 1,50 | 4.92 |
| TFC/F 2200 | 2,40 | 7.87 | 2,20 | 7.22 | 1,01 | 3.31 | 1,04 | 3.41 | 1,50 | 4.92 |

Standard equipment

- Universal three point linkage ISO cat 2.
- 1000 RPM PTO gearbox with overrun clutch.
- Structural steel frame.
- Hardox 400 lining.
- Hydraulically adjustable rear guard.
- Replaceable height-adjustable slids with wear resistant reinforcement.
- Single transmission with belt drive.
- Adjustable belt tensioners.
- Fixed "Ferri" tools: with tungsten carbide inserts.
- Front and rear guards with double chains.
- PTO shaft with shear bolt.
- PTO 1 3/8" = Z6.
- Double row of counter blades.
- Support stand.
- Accident prevention protections according to EC directives.

UTENSILI DA TAGLIO - CUTTING FLAILS

| Con rotore dedicato With dedicated rotor | TFC/F 1800 | TFC/F 2000 | TFC/F 2200 |  | | |
|--|---|------------|------------|---|------|------|
| | Nr. - No. | Nr. - No. | Nr. - No. | Ø cm | Ø in | |
| Utensili fissi reversibili con inserti al carburo di tungsteno Fixed and reversible tools with tungsten carbide inserts |  | 39 | 45 | 51 | 25 | 9.84 |

Accessories

- Push-over bar.

FERRI**TFC/A**

TRINCIATRICI FORESTALI - ROTORE CON UTENSILI FISSI
PER TRATTRICI DA 100 ÷ 140 HP (Ø max 25 cm - 9.84 in)
FORESTRY MULCHERS ROTOR WITH FIXED FLAILS
FOR TRACTORS FROM 100 to 140 HP (Ø max 25 cm - 9.84 in)

La gamma di potenti trinciatrici forestali TFC, è espressamente dedicata alla manutenzione del verde incolto e boscaglia, alla creazione e manutenzione di strade tagliafuoco, argini e ferrovie contaminati da arbusti, ecc. Le caratteristiche principali di queste macchine sono il telaio interamente in acciaio ad alto indice di snervamento, dal controltelaio interno rivestito in HARDOX 400 e dal rotore che, con mazze forgiate o utensili fissi, assicura un diametro di taglio fino a 25 cm. L'irrobustimento delle fiancate aumenta la tenuta del corpo macchina evitando possibili incrinature dovute a strappi e pressioni. Altri particolari importanti sono: il martinetto idraulico per apertura cofano, i 2 controcoltelli con spessore da 20 mm, le slitte di appoggio di grossa sezione, la trasmissione a 5 cinghie, le protezioni anteriori con 2 file di catene, ecc.



HARDOX[®]
WEAR PLATE

Rotore Apeiron con utensili fissi con inserti al carburo di tungsteno con profilo di acciaio
Apeiron rotor with fixed tools and tungsten carbide inserts with steel profile



The range of powerful forestry mulchers series TFC is specifically designed for the maintenance of set-aside areas, overgrown bushes, fire roads clearance, maintenance of embankments and railways side areas covered with heavy shrubs and so on, basically in all situations which can not be addressed with traditional agricultural shredders. The main features of these machines are: frame made of high yield steel, subframe made of wear-resistant steel (Hardox 400), a very versatile rotor whose forged hammers or fixed tooth, ensure a cutting diameter of up to 25 cm. The strong side plates increase the tightness of the main body, thus avoiding possible cracks due to tearing and torques. Other important details are: hydraulic cylinder for opening the hood, 2 thick counter-knives of 20 mm, wide side skids, side transmission with belts, front guards with 2 rows of chains and so on.



Rotore Apeiron con utensili fissi con inserti al carburo di tungsteno con profilo di acciaio.
 Apeiron rotor with fixed tools and tungsten carbide inserts with steel profile.



Controltelaio HARDOX 400.
 HARDOX 400 lining.



Trasmissione laterale a 5 cinghie e cofani con martinetti.
 Lateral 5-belt drive and hood with hydraulic cylinders.



Slitte di appoggio.
 Skids.



Doppia protezione anteriore con catene.
 Double front guard with chains.

INFORMAZIONI TECNICHE - TECHNICAL DATA

| Modello Model | | | | | | | | |
|------------------|------|------|-----------|----------|------|------|------|------|
| | m | ft | HP | KW | m | ft | m | lb |
| TFC/A 1800 | 1,80 | 5.90 | 100 - 120 | 75 - 90 | 0,28 | 0.92 | 0,50 | 1.64 |
| TFC/A 2000 | 2,00 | 6.56 | 120 - 130 | 90 - 97 | 0,28 | 0.92 | 0,50 | 1.64 |
| TFC/A 2200 | 2,20 | 7.22 | 120 - 140 | 90 - 104 | 0,28 | 0.92 | 0,50 | 1.64 |

| Modello Model | | | | |
|------------------|-------|---|-------|-------|
| | rpm | n | Kg | lb |
| TFC/A 1800 | 1.000 | 5 | 1.575 | 3.472 |
| TFC/A 2000 | 1.000 | 5 | 1.725 | 3.803 |
| TFC/A 2200 | 1.000 | 5 | 1.872 | 3.127 |

Dotazione standard

- Attacco universale a 3 punti ISO di 2° cat.
- Gruppo moltiplicatore pdf 1000 giri/min. con ruota libera.
- Telaio in acciaio strutturale.
- Controtelaio interno in "Hardox 400".
- Cofano posteriore regolabile idraulicamente.
- Slitte con rinforzo antiusura regolabili in altezza sostituibili.
- Trasmissione laterale singola a cinghie.
- Tendinginghie regolabile.
- Utensili fissi: con inserti al carburo di tungsteno.
- Protezione anteriore e posteriore con catene doppie.
- Albero cardanico con bullone di trancio.
- Presa di forza 1 3/8" = Z6.
- Doppia fila di controcoltelli.
- Piedino di appoggio.
- Protezioni antifortunistiche «CE».

Accessori

- Abbattirami.

Standard equipment

- Universal three point linkage ISO cat 2.
- 1000 RPM PTO gearbox with overrun clutch.
- Structural steel frame.
- Hardox 400 lining.
- Hydraulically adjustable rear guard.
- Replaceable height-adjustable slids with wear resistant reinforcement.
- Single transmission with belt drive.
- Adjustable belt tensioners.
- Fixed "Ferri" tools: with tungsten carbide inserts.
- Front and rear guards with double chains.
- PTO shaft with shear bolt.
- PTO 1 3/8" = Z6.
- Double row of counter blades.
- Support stand.
- Accident prevention protections according to EC directives.

DIMENSIONI - DIMENSIONS

| | T | | L | | P | | H1 | | H2 | |
|------------|------------|------|------|------|------|------|------|------|------|------|
| | m | ft | m | ft | m | ft | m | ft | m | ft |
| | TFC/A 1800 | 2,00 | 6.56 | 1,80 | 5.91 | 1,01 | 3.31 | 1,04 | 3.41 | 1,50 |
| TFC/A 2000 | 2,20 | 7.22 | 2,00 | 6.56 | 1,01 | 3.31 | 1,04 | 3.41 | 1,50 | 4.92 |
| TFC/A 2200 | 2,40 | 7.87 | 2,20 | 7.22 | 1,01 | 3.31 | 1,04 | 3.41 | 1,50 | 4.92 |

UTENSILI DA TAGLIO - CUTTING FLAILS

| Con rotore dedicato With dedicated rotor | TFC/A 1800 | TFC/A 2000 | TFC/A 2200 | | | |
|--|------------|------------|------------|------|------|------|
| | Nr. - No. | Nr. - No. | Nr. - No. | Ø cm | Ø in | |
| Utensili fissi reversibili con inserti al carburo di tungsteno Fixed and reversible tools with tungsten carbide inserts | | 39 | 45 | 51 | 25 | 9.84 |

Accessories

- Push-over bar.

FERRI[®]**TFC-DT/F****VOTEX**[®]

TRINCIATRICI FORESTALI DOPPIA TRASMISSIONE - ROTORE CON UTENSILI FISSI
PER TRATTRICI (150÷250 HP) (Ø max 40 cm - 15.75 in)
FORESTRY MULCHERS DOUBLE TRANSMISSION ROTOR WITH FIXED FLAILS
FOR TRACTORS (150-250 HP) (Ø max 40 cm - 15.75 in)



HARDOX[®]
 WEAR PLATE

Rotore con utensili fissi
Rotor with fixed tools



La gamma di potenti trinciatrici forestali TFC, è espressamente dedicata alla manutenzione del verde incolto e boscaglia, alla creazione e manutenzione di strade tagliafuoco, argini e ferrovie contaminati da arbusti, ecc. Le caratteristiche principali di queste macchine sono il telaio interamente in acciaio ad alto indice di snervamento, dal controtelaio interno rivestito in HARDOX 400 e dal rotore che, con mazze forgiate o utensili fissi, assicura un diametro di taglio fino a 40 cm. L'irrobustimento delle fiancate aumenta la tenuta del corpo macchina evitando possibili incrinature dovute a strappi e pressioni. Altri particolari importanti sono: il martinetto idraulico per apertura cofano, i 2 controcotelli con spessore da 20 mm, le slitte di appoggio di grossa sezione, la trasmissione a 10 cinghie, le protezioni anteriori con 2 file di catene, ecc.

The range of powerful forestry mulchers series TFC is specifically designed for the maintenance of set-aside areas, overgrown bushes, fire roads clearance, maintenance of embankments and railway side areas covered with heavy shrubs and so on, basically in all situations which can not be addressed with traditional agricultural shredders. The main features of these machines are: frame made of high yield steel, subframe made of wear-resistant steel (Hardox 400), a very versatile rotor whose forged hammers or fixed tooth, ensure a cutting diameter of up to 40 cm. The strong side plates increase the tightness of the main body, thus avoiding possible cracks due to tearing and torques. Other important details are: hydraulic cylinder for opening the hood, 2 thick counter-knives of 20 mm, wide side skids, side transmission with 10 belts, front guards with 2 rows of chains and so on.



Rotore con utensili fissi.
 Rotor with fixed tools.



Controtelaio HARDOX 400.
 HARDOX 400 lining.



Doppia trasmissione laterale a 5 + 5 cinghie e cofani con martinetti.
 Double lateral drive with 5+5 belts and hood with hydraulic cylinders.



Slitte di appoggio.
 Skids.



Doppia protezione anteriore con catene.
 Double front guard with chains.

INFORMAZIONI TECNICHE - TECHNICAL DATA

| Modello Model | | | | | | | | |
|------------------|------|------|-----------|-----------|------|------|------|------|
| | m | ft | HP | kW | m | ft | m | lb |
| TFC-DT/F 2000 | 2,00 | 6.56 | 150 - 200 | 112 - 149 | 0,28 | 0,92 | 0,50 | 1.64 |
| TFC-DT/F 2200 | 2,20 | 7.22 | 200 - 250 | 149 - 186 | 0,28 | 0,92 | 0,50 | 1.64 |

| Modello Model | | | | |
|------------------|-------|-------|-------|-------|
| | rpm | n | Kg | lb |
| TFC-DT/F 2000 | 1.000 | 5 + 5 | 1.870 | 4.123 |
| TFC-DT/F 2200 | 1.000 | 5 + 5 | 2.080 | 4.586 |

DIMENSIONI - DIMENSIONS

| | T | | L | | P | | H1 | | H2 | |
|---------------|---------------|------|------|------|------|------|------|------|------|------|
| | m | ft | m | ft | m | ft | m | ft | m | ft |
| | TFC-DT/F 2000 | 2,40 | 7.87 | 2,00 | 6.56 | 1,01 | 3.31 | 1,04 | 3.41 | 1,50 |
| TFC-DT/F 2200 | 2,60 | 8.53 | 2,20 | 7.22 | 1,01 | 3.31 | 1,04 | 3.41 | 1,50 | 4.92 |

UTENSILI DA TAGLIO - CUTTING FLAILS

| Con rotore dedicato With dedicated rotor | | TFC-DT/F 2000 | TFC-DT/F 2200 | | |
|--|--|---------------|---------------|------|-------|
| | | Nr. - No. | Nr. - No. | Ø cm | Ø in |
| Utensili fissi reversibili con inserti al carburo di tungsteno Fixed and reversible tools with tungsten carbide inserts | | 45 | 51 | 40 | 15.75 |

Dotazione standard

- Attacco universale a 3 punti ISO di 2° cat.
- Gruppo moltiplicatore pdf 1000 giri/min. con ruota libera.
- Telaio in acciaio strutturale.
- Controtelaio interno in "Hardox 400".
- Coffano posteriore regolabile idraulicamente.
- Slitte con rinforzo antiusura regolabili in altezza sostituibili.
- Trasmissione laterale doppia a cinghie.
- Tendinghie regolabile.
- Utensili fissi con inserti al carburo di tungsteno.
- Protezione anteriore e posteriore con catene doppie.
- Albero cardanico con bullone di trancio.
- Presa di forza 1 3/4" = Z6.
- Doppia fila di controcoltelli.
- Piedino di appoggio.
- Protezioni antifortunistiche «CE».

Accessori

- Abbattirami meccanico per TFC-DT/F 2000 - 2200
- Abbattirami idraulico per TFC-DT/F 2000 - 2200.

Standard equipment

- Universal three point linkage ISO cat 2.
- 1000 RPM PTO gearbox with overrun clutch.
- Structural steel frame.
- Hardox 400 lining.
- Hydraulically adjustable rear guard.
- Replaceable height-adjustable skids with wear resistant reinforcement.
- Support stand.
- Double transmission with belt drive
- Adjustable belt tensioners.
- Fixed tools with tungsten carbide inserts.
- Front and rear guards with double chains.
- PTO shaft with shear bolt.
- PTO 1 3/4" = Z6.
- Double row of counter blades.
- Accident prevention protections according to EC directives.

Accessories

- Mechanical push-over bar for TFC-DT/F 2000 - 2200
- Hydraulic push-over bar for TFC-DT/F 2000 - 2200.

FERRI[®]**TFC-DT/A**

**TRINCIATRICI FORESTALI DOPPIA TRASMISSIONE - ROTORE CON UTENSILI FISSI
PER TRATTRICI (150÷250 HP) (Ø max 40 cm - 15.75 in)
FORESTRY MULCHERS DOUBLE TRANSMISSION ROTOR WITH FIXED FLAILS
FOR TRACTORS (150-250 HP) (Ø max 40 cm - 15.75 in)**



HARDOX[®]
WEAR PLATE

**Rotore Apeiron con utensili fissi con inserti al carburo di tungsteno con profilo di acciaio
Apeiron rotor with fixed tools and tungsten carbide inserts with steel profile**

La gamma di potenti trinciatrici forestali TFC, è espressamente dedicata alla manutenzione del verde incolto e boscaglia, alla creazione e manutenzione di strade tagliafuoco, argini e ferrovie contaminati da arbusti, ecc. Le caratteristiche principali di queste macchine sono il telaio interamente in acciaio ad alto indice di snervamento, dal controtelaio interno rivestito in HARDOX 400 e dal rotore che, con mazze forgiate o utensili fissi, assicura un diametro di taglio fino a 40 cm. L'irrobustimento delle fiancate aumenta la tenuta del corpo macchina evitando possibili incrinature dovute a strappi e pressioni. Altri particolari importanti sono: il martinetto idraulico per apertura cofano, i 2 controcoltelli con spessore da 20 mm, le slitte di appoggio di grossa sezione, la trasmissione a 10 cinghie, le protezioni anteriori con 2 file di catene, ecc.



The range of powerful forestry mulchers series TFC is specifically designed for the maintenance of set-aside areas, overgrown bushes, fire roads clearance, maintenance of embankments and railway side areas covered with heavy shrubs and so on, basically in all situations which can not be addressed with traditional agricultural shredders. The main features of these machines are: frame made of high yield steel, subframe made of wear-resistant steel (Hardox 400), a very versatile rotor whose forged hammers or fixed tooth, ensure a cutting diameter of up to 40 cm. The strong side plates increase the tightness of the main body, thus avoiding possible cracks due to tearing and torques. Other important details are: hydraulic cylinder for opening the hood, 2 thick counter-knives of 20 mm, wide side skids, side transmission with 10 belts, front guards with 2 rows of chains and so on.

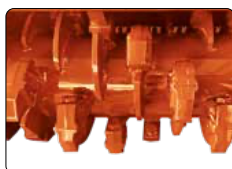

Rotore Apeiron con utensili fissi con inserti al carburo di tungsteno con profilo di acciaio.
Apeiron rotor with fixed tools and tungsten carbide inserts with steel profile.



Controtelaio HARDOX 400.
HARDOX 400 lining.



Doppia trasmissione laterale a 5 + 5 cinghie e cofani con martinetti.
Double lateral drive with 5+5 belts and hood with hydraulic cylinders.



Slitte di appoggio.
Skids.



Doppia protezione anteriore con catene.
Double front guard with chains.

INFORMAZIONI TECNICHE - TECHNICAL DATA

| Modello Model | | | | | | | | |
|------------------|------|------|-----------|-----------|------|------|------|------|
| | m | ft | HP | kW | m | ft | m | lb |
| TFC-DT/A 2000 | 2,00 | 6.56 | 150 - 200 | 112 - 149 | 0,28 | 0,92 | 0,50 | 1.64 |
| TFC-DT/A 2200 | 2,20 | 7.22 | 200 - 250 | 149 - 186 | 0,28 | 0,92 | 0,50 | 1.64 |

| Modello Model | | | | |
|------------------|-------|-------|-------|-------|
| | rpm | n | Kg | lb |
| TFC-DT/A 2000 | 1.000 | 5 + 5 | 1.925 | 4.244 |
| TFC-DT/A 2200 | 1.000 | 5 + 5 | 2.142 | 4.722 |

DIMENSIONI - DIMENSIONS

| | T | | L | | P | | H1 | | H2 | |
|----------------------|----------------------|------|------|------|------|------|------|------|------|------|
| | m | ft | m | ft | m | ft | m | ft | m | ft |
| | TFC-DT/A 2000 | 2,40 | 7.87 | 2,00 | 6.56 | 1,01 | 3.31 | 1,04 | 3.41 | 1,50 |
| TFC-DT/A 2200 | 2,60 | 8.53 | 2,20 | 7.22 | 1,01 | 3.31 | 1,04 | 3.41 | 1,50 | 4.92 |

UTENSILI DA TAGLIO - CUTTING FLAILS

| Con rotore dedicato With dedicated rotor | | TFC-DT/A 2000 | TFC-DT/A 2200 | | |
|--|--|---------------|---------------|------|-------|
| | | Nr. - No. | Nr. - No. | Ø cm | Ø in |
| Utensili fissi reversibili con inserti al carburo di tungsteno Fixed and reversible tools with tungsten carbide inserts | | 45 | 51 | 40 | 15.75 |

Dotazione standard

- Attacco universale a 3 punti ISO di 2° cat.
- Gruppo moltiplicatore pdf 1000 giri/min. con ruota libera.
- Telaio in acciaio strutturale.
- Controtelaio interno in "Hardox 400".
- Coffano posteriore regolabile idraulicamente.
- Slitte con rinforzo antiusura regolabili in altezza sostituibili.
- Trasmissione laterale doppia a cinghie.
- Tendinghie regolabile.
- Utensili fissi con inserti al carburo di tungsteno.
- Protezione anteriore e posteriore con catene doppie.
- Albero cardanico con bullone di trancio.
- Presa di forza 1 3/4" = Z6.
- Doppia fila di controcoltelli.
- Piedino di appoggio.
- Protezioni antifortunistiche «CE».

Accessori

- Abbattirami meccanico per TFC-DT/A 2000 - 2200.
- Abbattirami idraulico per TFC-DT/A 2000 - 2200.

Standard equipment

- Universal three point linkage ISO cat 2.
- 1000 RPM PTO gearbox with overrun clutch.
- Structural steel frame.
- Hardox 400 lining.
- Hydraulically adjustable rear guard.
- Replaceable height-adjustable skids with wear resistant reinforcement.
- Support stand.
- Double transmission with belt drive
- Adjustable belt tensioners.
- Fixed tools with tungsten carbide inserts.
- Front and rear guards with double chains.
- PTO shaft with shear bolt.
- PTO 1 3/4" = Z6.
- Double row of counter blades.
- Accident prevention protections according to EC directives.

Accessories

- Mechanical push-over bar for TFC-DT/A 2000 - 2200.
- Hydraulic push-over bar for TFC-DT/A 2000 - 2200.



A series of horizontal lines for writing, consisting of 25 evenly spaced lines that span the width of the page.



I dati tecnici riportati ed i modelli descritti si intendono non impegnativi. Per fini migliorativi il Costruttore si riserva il diritto di modifiche, senza preavviso.

Disegni e fotografie possono riferirsi a equipaggiamenti opzionali o ad allestimenti destinati ad altri Paesi. Per ogni altra informazione, rivolgersi alla nostra rete di vendita.

The technical specifications indicated and models described are not binding. For the purpose of making improvements, the manufacturer reserves the right to make changes to them without prior notice. Drawings and photographs may refer to optional equipment or configurations intended for other countries. If you require further information, please contact our sales network.



VOTEX UK LTD

Redhill Depot, Ross Road, Hereford HR2 8BH
Tel: 01432 274361 e-mail: sales@votex.co.uk
www.votex.co.uk



FERRI srl

Via C. Govoni, 30 44034 TAMARA (Ferrara) Italy
Tel. + 39 0532.866 866 - Fax + 39 0532.866 851
info@ferrisrl.it
www.ferrisrl.it



Follow Us

